

L1634

STN Reflective type

Item	L163400J000
Mechanical Characteristics	A
Absolute Maximum Ratings	B
Electrical Characteristics	C
Optical Characteristics	D-1
Recommended Operating Voltage	E

F-1 Power Supply

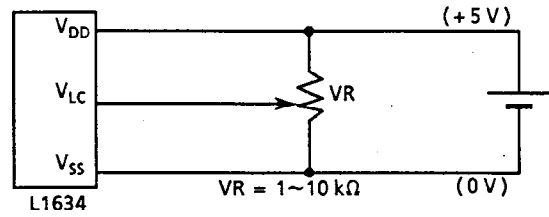

F-2 Dimensions

Unit : mm

General tolerance : ± 0.5

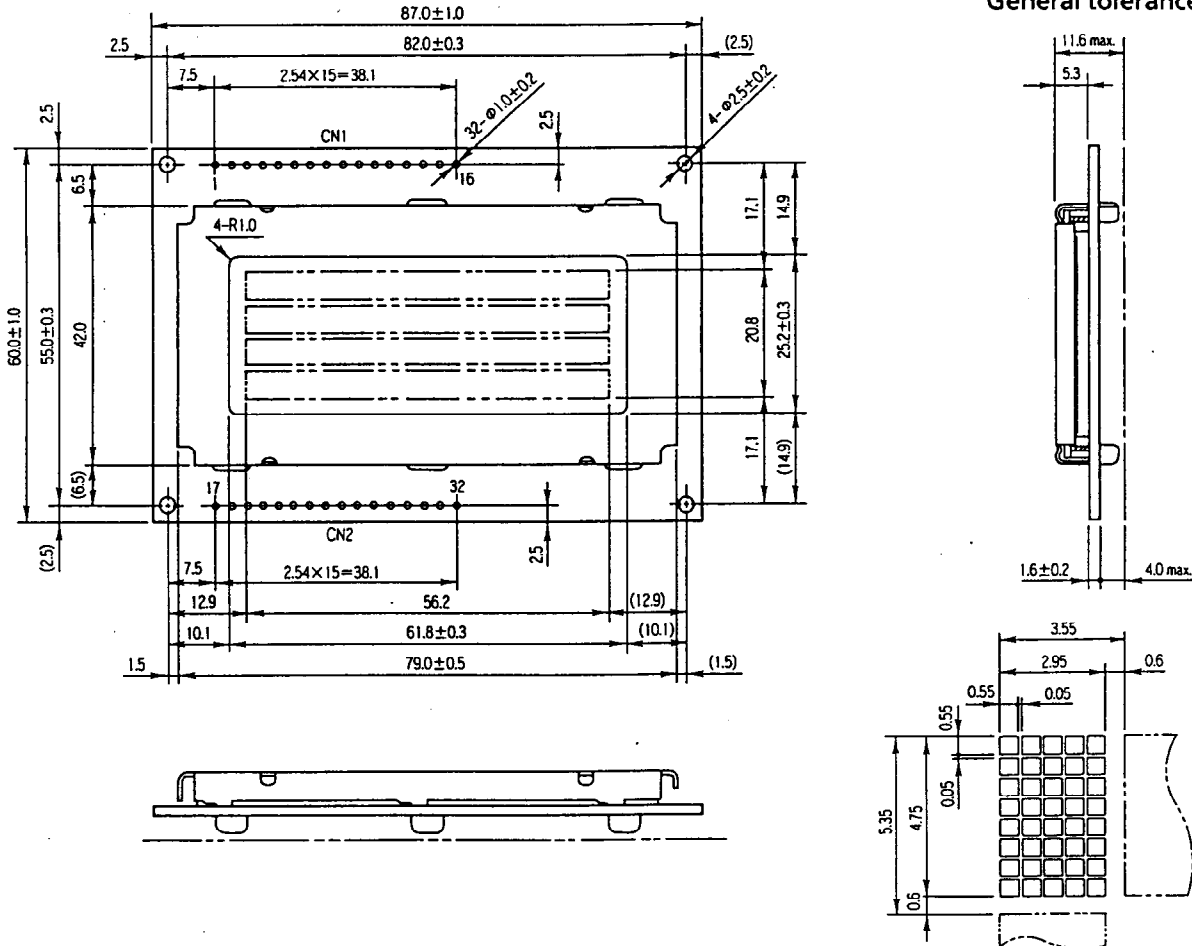

F-3 Pin Functions

No.	No.	Name	Function
1	17	V _{SS}	GND
2	18	V _{DD}	Power supply voltage + 5 V
3	19	V _{LC}	Liquid crystal driving voltage
4	20	RS	L: Instruction code input H: Data input
5	21	R/W	L: Data write (LCM → MPU) H: Data read (LCM → MPU)
6	22	E	Enable
7	23	DB ₀	Data bus line
8	24	DB ₁	Data bus line
9	25	DB ₂	Data bus line
10	26	DB ₃	Data bus line
11	27	DB ₄	Data bus line
12	28	DB ₅	Data bus line
13	29	DB ₆	Data bus line
14	30	DB ₇	Data bus line
15	31	NC	-
16	32	NC	-

F-4 Block Diagram

